

4220153 - INSTRUCTIONS FOR THE NEW ADA MONETARY AREA

PROCEDURE FOR INSTALLING A COIN CHANGER

PLEASE READ THROUGH ALL THE INSTRUCTIONS

1. Mount the changer unit onto the 3 screws provided (see **fig.1a**) and then secure.
NOTE: Most units should be mounted using the center set of holes. Check the alignment between the coin entry chute and the entry hopper on the unit to determine the best alignment, use the LH or RH mounting holes if needed.
2. Check the relationship between the underside of the coin changer and the top surface of the coin cup area, ensure there is a clearance of approximately 3/16" between them; pull/push the coin unit out/in to ensure there is no interference between the underside of the coin mechanism and the coin cup deflector. Adjust the coin unit mounting assembly up/down by slackening/tightening the nuts shown in **fig.1b**.
3. Check the relationship between the underside of the coin entry chute and the top surface of the coin entry hopper to ensure there is minimum clearance between them. Insert the largest and smallest physical coins to verify there is clear passage. Adjust the coin entry chute up/down by slackening/tightening the nuts shown in **fig.2**. Also consider the adjustment in Step 1 which may provide a better solution.
4. With the machine switched ON and the coin changer housing pushed firmly home, push the coin return button to check the operation of the coin return motor (see **fig.2**). Ensure that the reject lever on the coin mechanism is actuated sufficiently to clear bent coins. If the stroke of the coin return roller arm needs to be increased/decreased, adjust by slackening/tightening the screws shown in **fig.3**.

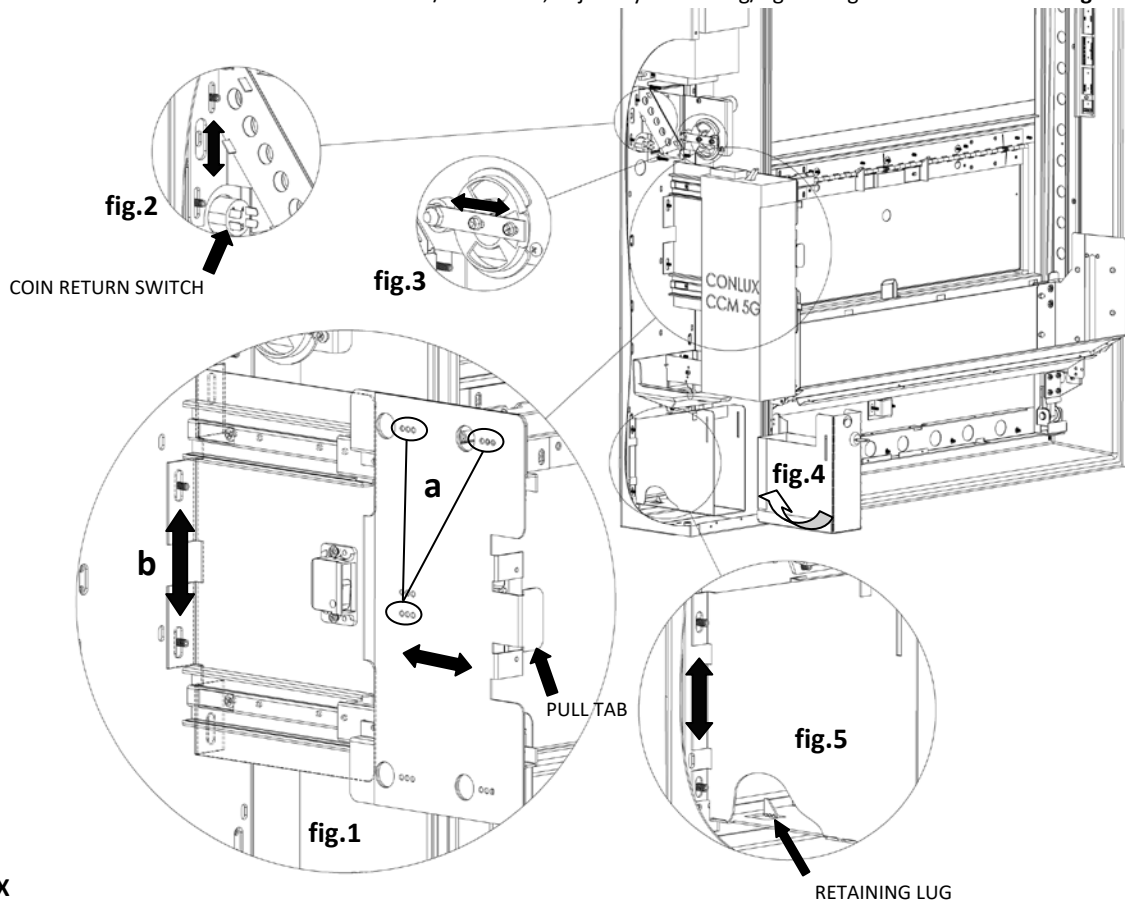

CASH BOX

1. To remove the cash box tilt the box slightly upwards (see **fig.4**) at the front to disengage it from the retaining lug on the floor (see **fig.5**) of the housing before attempting to slide it out.
2. When returning the cash box again tilt it slightly upwards at the front and when pushed full-in allow the cash box to sit down and ensure the retaining lug has engaged by pulling/tugging on the box without lifting.

IMPORTANT:

1. Ensure that the coin unit is pushed fully home after servicing, a positive 'click' will be felt when this is achieved. Failure to do this will result in coins becoming jammed etc.
2. DO NOT attempt to close the main door when the coin unit is pulled-out.
3. Ensure the cash box is located fully into its housing before closing the main door.